

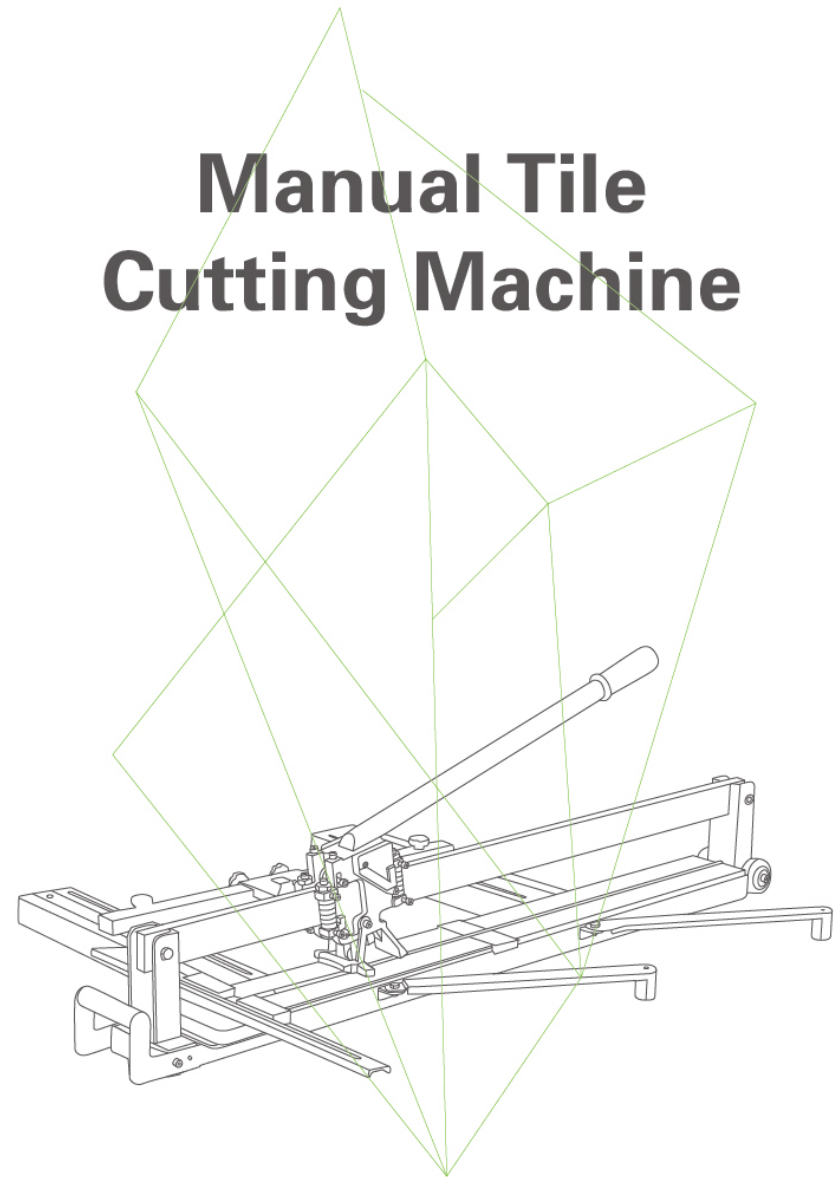

# Manual tile cutter

• Installation instruction •

# Manual Tile Cutting Machine



***Make work easier***

• Installation instruction •

Please read the instructions carefully before installing and using this product.  
All instructions and keep this manual in good order

# Using Method

## 1. Location

Move the scale to select cutting size. Use one hand to hold the operating handle. Pull the knife wheel to backseat. Place the tile on the baseboard horizontally and align the cutting line of the tile and the beam of the baseboard. Make front end of the tile on the opening of the baseboard.



## 2. Marking Off

Place the handle to make the knife wheel contact tile surface. Push the handle forward gently to make the knife wheel cut a continuous and even straight line on tile surface.



## 3. Cutting Open

Press down to lift the operating handle slightly backwards, to make the briquetting on the front end of the tile stably. Press the operating handle downwards properly, the tile will fracture along the marked line.



# Suggestion

Whether the marked line is even, continuous and clear all the way is the key whether it can cut the tile properly. The knife wheel is made from special super hard alloy, whose hardness far exceeds that of tile surface. Therefore, it can mark a cutting line only by using very small force to hold the handle to push the knife wheel gently and smoothly. In the process of cutting the tile, the main force is not on marking off, which is the same as cutting glass. Marking off too strongly does not only make the cutting line become sawtooth, but also makes break of yellow blade of super hard alloy, which greatly reduces normal service life of the knife wheel.

## TG-01



Model	800	1000	1200
↔ Maximum cutting width:	800mm	1000mm	1200mm
↔ Minimum cutting width:	35mm	35mm	35mm
⊞ Maximum cutting thickness:	6-15mm	6-15mm	6-15mm

## S500



Model	800	1000
↔ Maximum cutting width:	800mm	1000mm
↔ Minimum cutting width:	35mm	35mm
⊞ Maximum cutting thickness:	6-15mm	6-15mm

## D-01



Model	600	800	1000	1200
↔ Maximum cutting width:	600mm	800mm	1000mm	1200mm
↔ Minimum cutting width:	35mm	35mm	35mm	35mm
⊞ Maximum cutting thickness:	6-15mm	6-15mm	6-15mm	6-15mm

## G-01



Model	800	1000	1200
↔ Maximum cutting width:	800mm	1000mm	1200mm
↔ Minimum cutting width:	35mm	35mm	35mm
⊞ Maximum cutting thickness:	6-15mm	6-15mm	6-15mm